

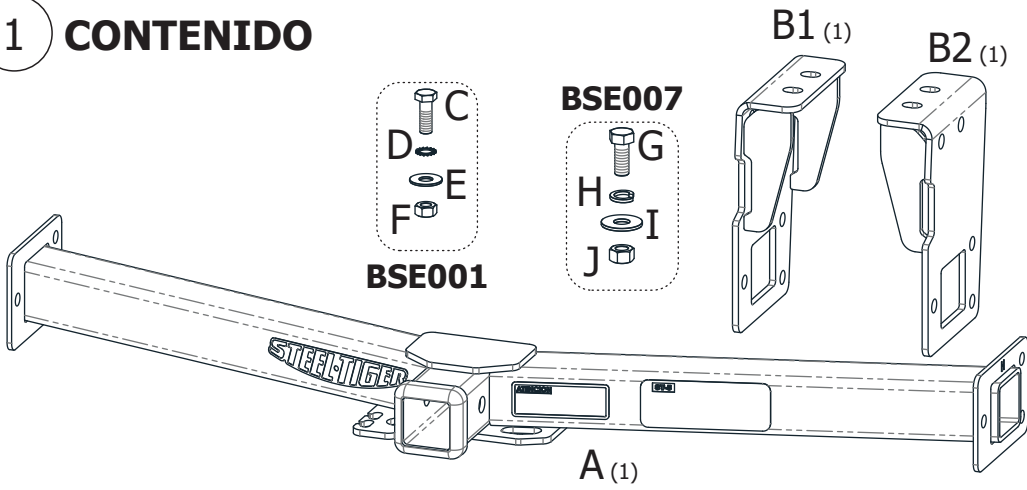

### 1 CONTENIDO

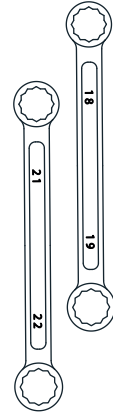

### 2 HERRAMIENTAS NECESARIAS



### 3 COLOCACIÓN DE PIEZAS "B1" Y "B2"

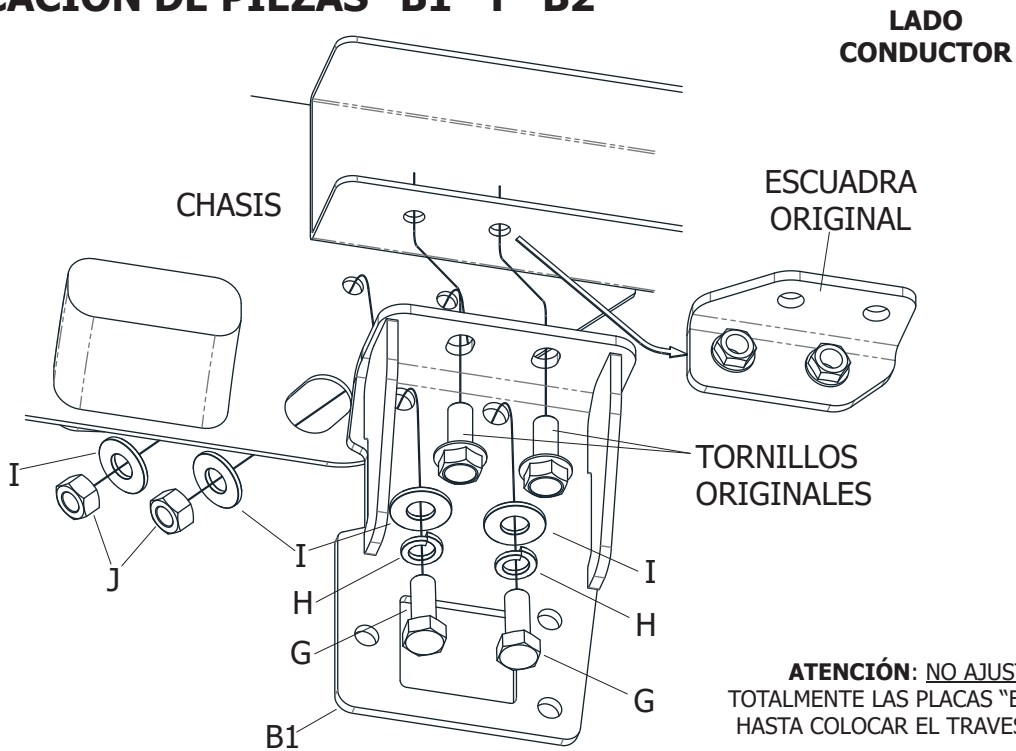

### 4 COLOCACIÓN DE PIEZA "A"

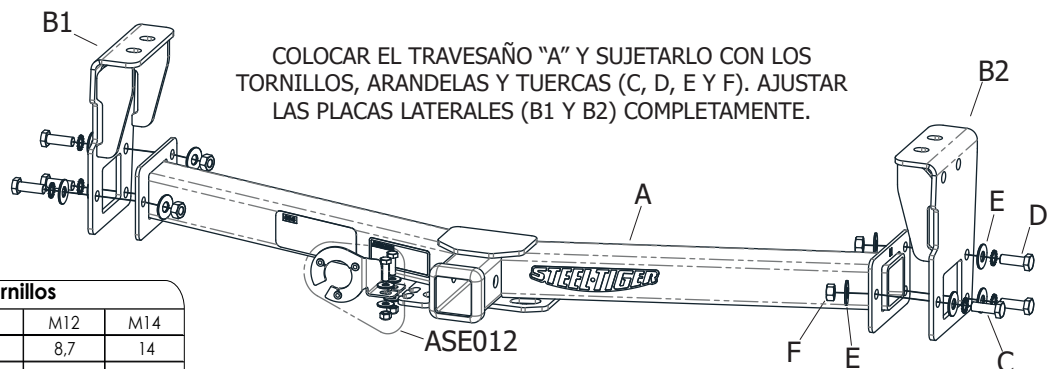

Valores de apriete de tornillos

Unidades	M4	M6	M8	M10	M12	M14
Kg.m	0,3	1	2,5	5,1	8,7	14
Coeficiente de fricción: $\mu=0,14$						